



Hybrid Wireless Network on Chip: A New Paradigm in Multi-Core Design

Partha Pratim Pande and Colleagues

Outline

- Introduction
 - Multi-core & Network-on-Chip paradigm
- Performance limitations of conventional planar NoCs
 - Some alternatives
- Possibility of designing wireless NoC (WiNoC)
 - CNT-based antennas
- Possible communication schemes
- Advantages and challenges of WiNoCs
- Summary and road ahead



Multi-core applications



Nokia Sparrow



The \$3995 Parallax Propeller QuadRover robot is controlled by the multicore Propeller chip.

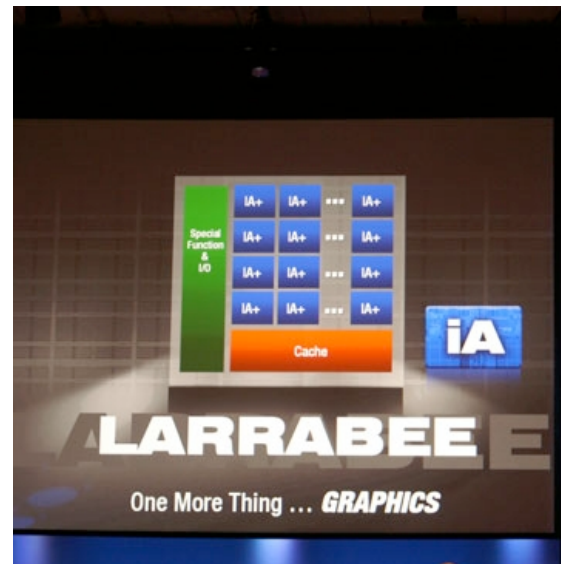

Intel LARRABEE

The network-on-chip paradigm

- Driven by
 - Increased levels of integration
 - Complexity of large SoCs
 - New designs counting 100s of embedded cores
 - Need for platform-based design methodologies
 - DSM constraints (power, delay, time-to-market, etc...)

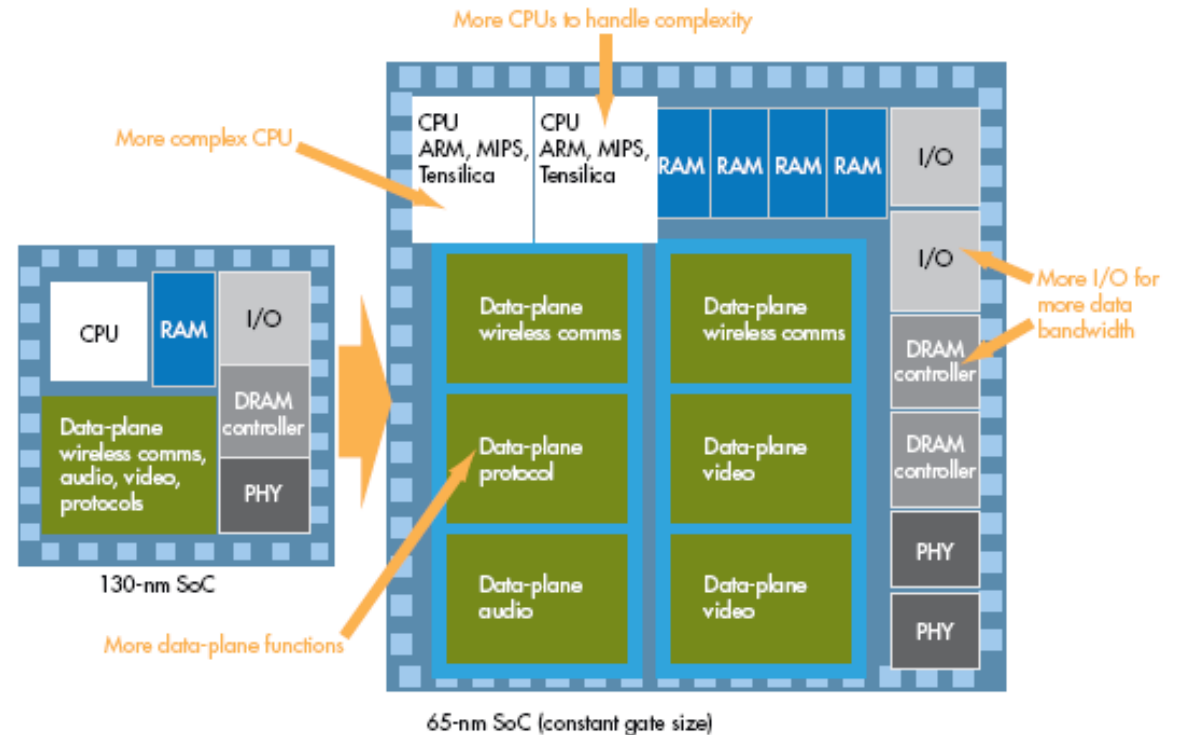

NoC features

- Decoupling of functionality from communication
- Dedicated infrastructure for data transport

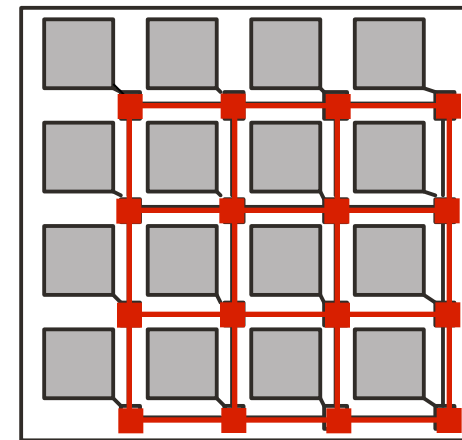
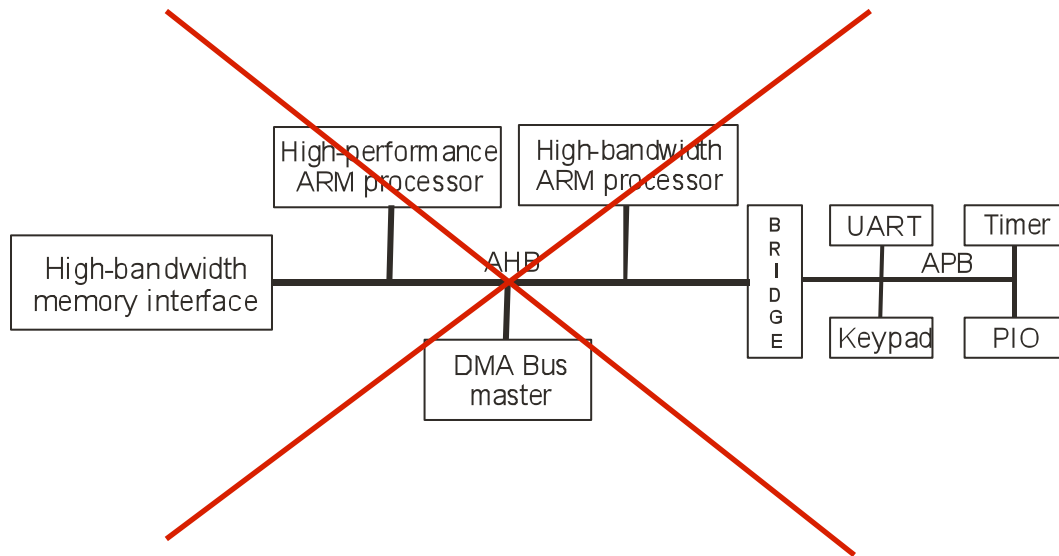

NoC infrastructure

■ switch — link

NoC limitations

- Predominantly multi-hop communication
 - High Latency and energy dissipation
- Use of Express Virtual Channels

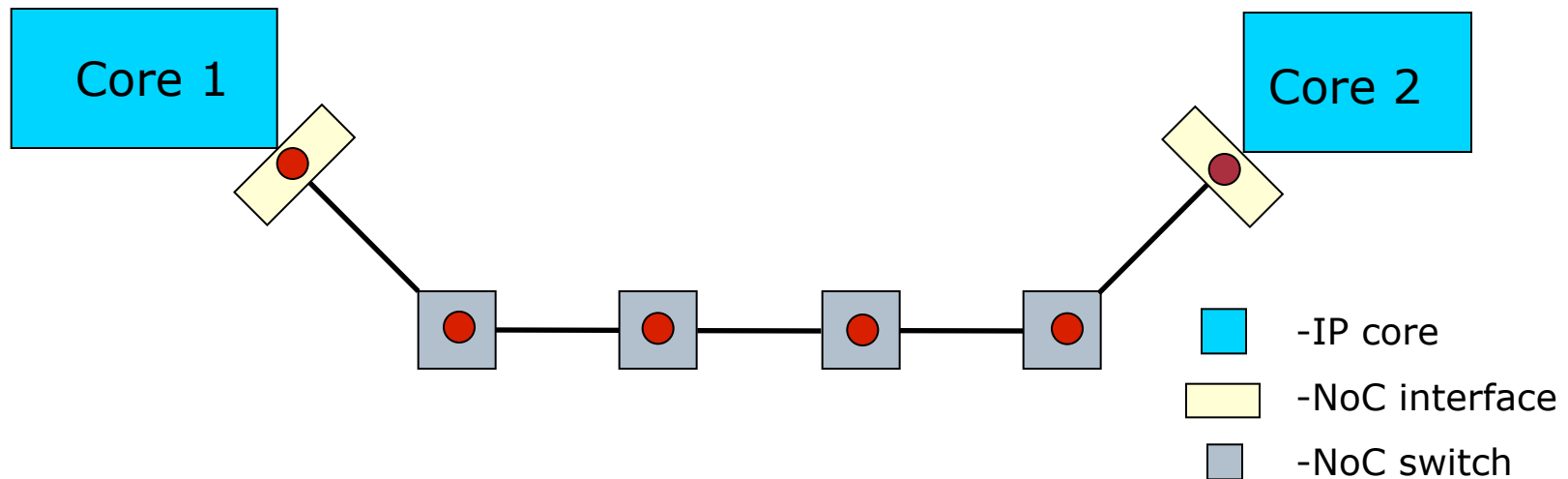

Novel interconnect paradigms for Multicore designs

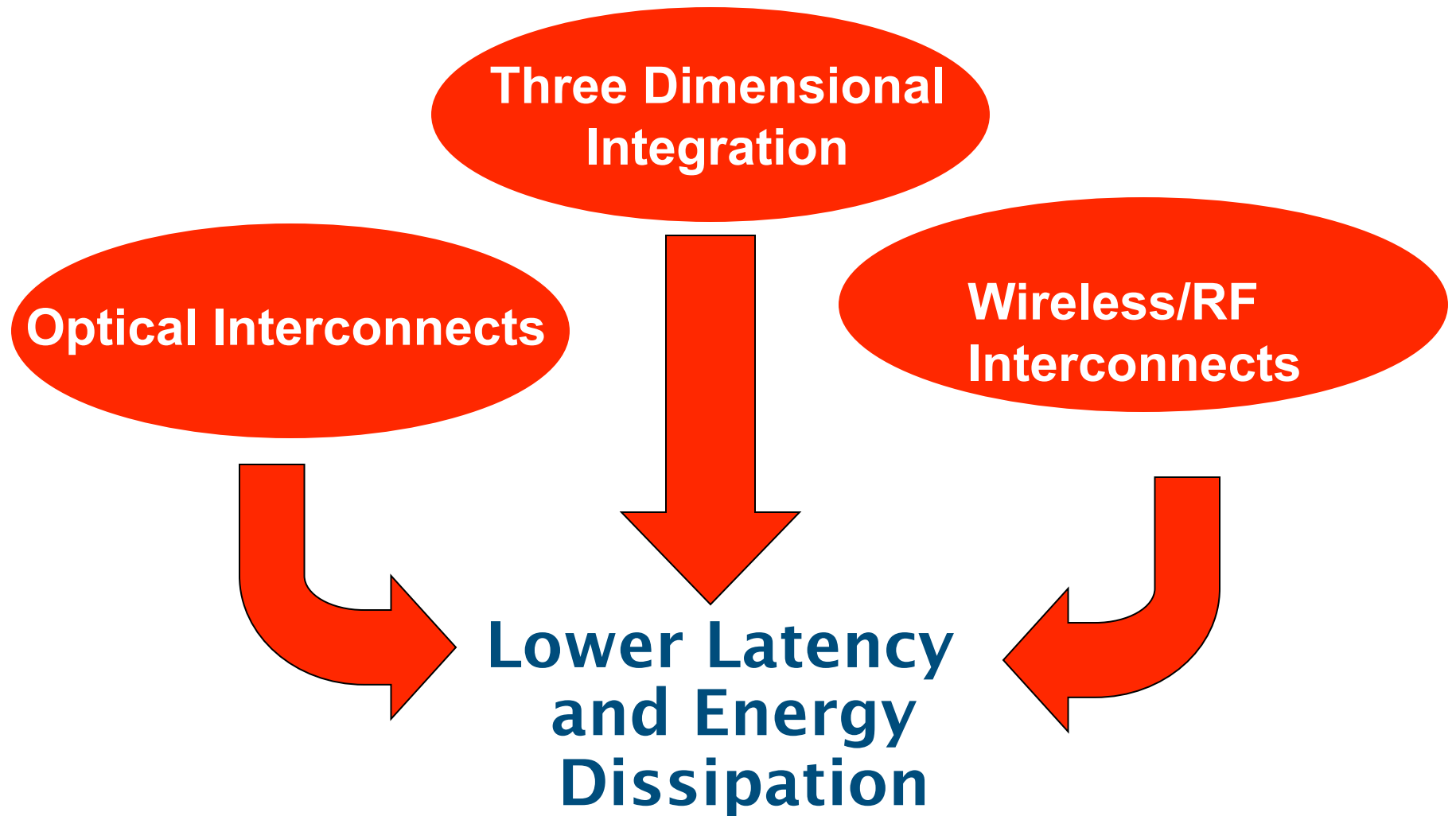

3D NoC

- Stacking multiple active layers
- Manufacturability
 - Mismatch between various layers
 - Yield is currently quite low
- Temperature concerns
 - Despite power advantages, reduced footprint increases power density

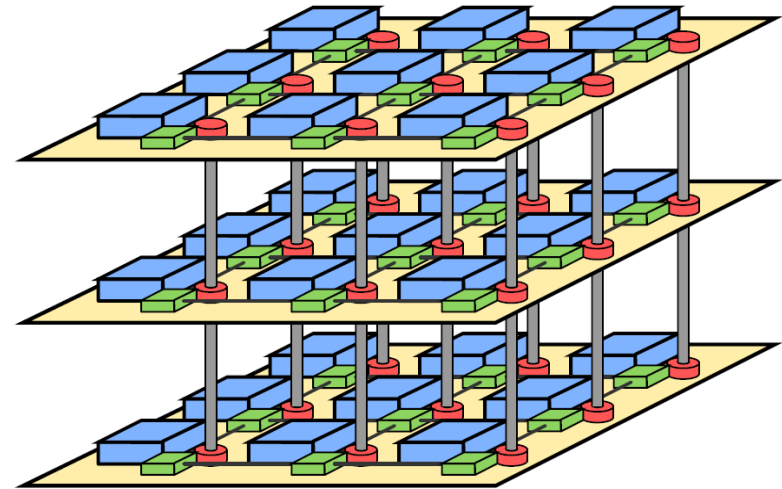

- Brett S. Feero, Partha Pratim Pande, "Networks-On-Chip in a Three Dimensional Environment: A Performance Evaluation", IEEE Transactions on Computers (TC), vol.58, no. 1, pp. 32-45, January 2009.

Photonic NoC

- High bandwidth photonic links for high payload transfers
- Limitations on switch architecture
 - More than 4-port designs are complex
- On-chip integration of photonic components

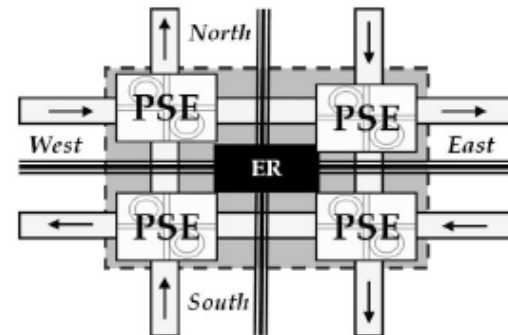
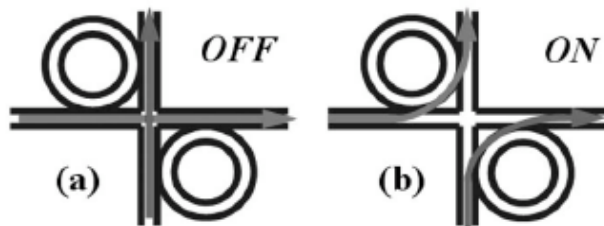

- A. Shacham et al., "Photonic Network-on-Chip for Future Generations of Chip Multi-Processors", IEEE Transactions on Computers, Vol. 57, issue 9, pp. 1246-1260.

On-Chip RF/Wireless Interconnects

- Replace long distance wires
- Use of waveguides out of package or IC structures like parallel metal wires
- Chang et al. demonstrated Transmission Line based RF interconnect for on chip communication
 - Not really wireless

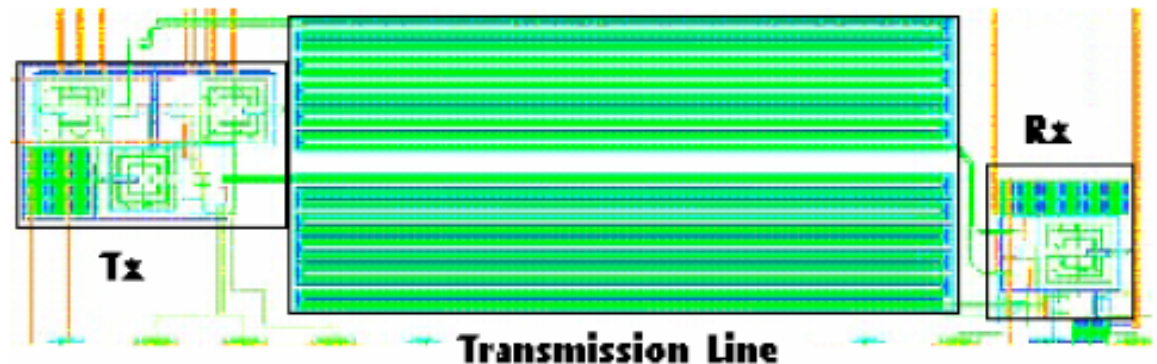

RF NoC

- Bank of high frequency oscillators and filters
- FDM
- On-Chip transmission line acting as data freeways
- Routing of long transmission lines without eliminating any existing links

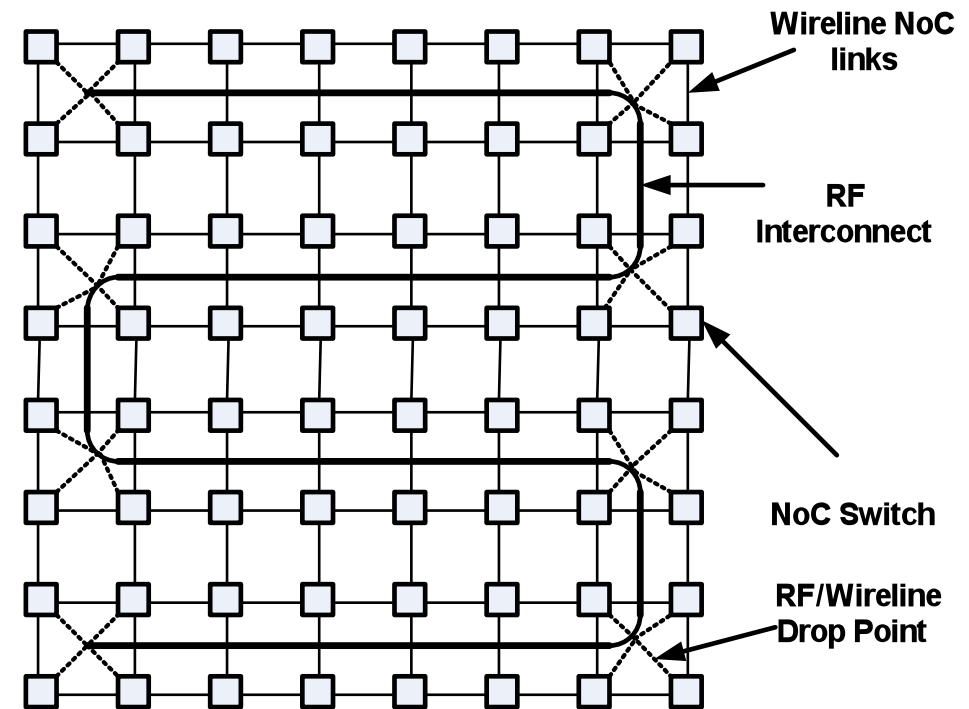

- M. F. Chang et al. "CMP Network-on-Chip Overlaid With Multi-Band RF-Interconnect", Proc. of IEEE International Symposium on High-Performance Computer Architecture, 16-20 February, 2008, pp. 191-202.

Wireless Network-on-Chip (WiNoC)

- ❑ **Use of on-chip wireless links**

- **High bandwidth**
- **Speed of light**
- **Long distance**

- ❑ **Reduce latency and energy dissipation in communication between distant nodes**

- ❑ **Among several options, some may be possible without a revolutionary technology**



Early example of on-chip wireless interconnects

- First utilized for distribution of clock signal
 - Technology: 0.18 μm CMOS
 - Operating frequency: 15 GHz
- Single Tone
 - Modulation and Channelization is not of any concern

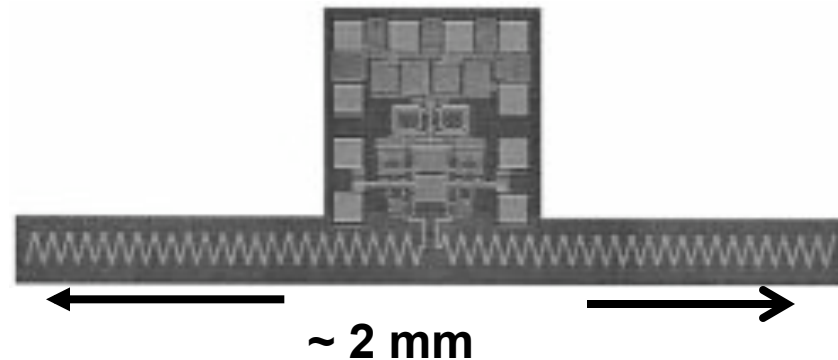
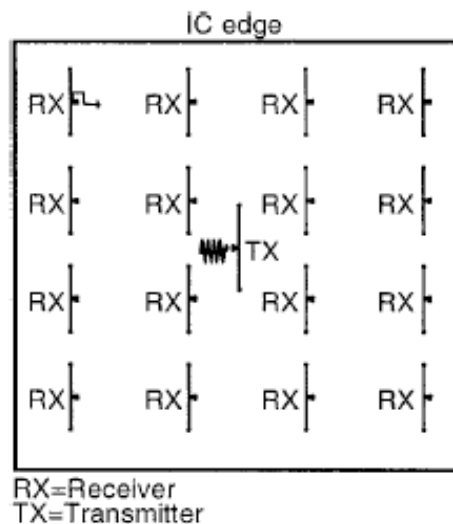

- B. A. Floyd, H. Chih-Ming, and K. K. O, *IEEE Journal of Solid-State Circuits*, vol. 37, pp. 543-552, 2002.

Propagation mechanisms of radio waves over intra-chip channels

- Characterization of on-chip radio communications
- Monopole Antennas
- Measurement is done for the frequency range of 10 – 100 GHz

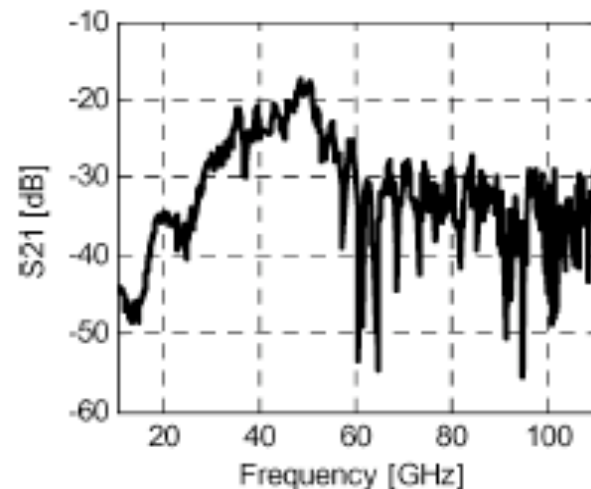

- Y. P. Zhang et al., "Propagation Mechanisms of Radio Waves Over Intra-Chip Channels with Integrated Antennas: Frequency-Domain Measurements and Time-Domain Analysis", IEEE Transactions on Antennas and Propagation, Vol. 55, No. 10, October 2007, pp. 2900-2906.

CNT antennas

- To make the antennas small, we need small wavelengths → light (IR, visible, UV)
- MWCNT as Optical Antennae
- Directional radiation characteristics are in an excellent and quantitative agreement with conventional radio antenna theory and simulations

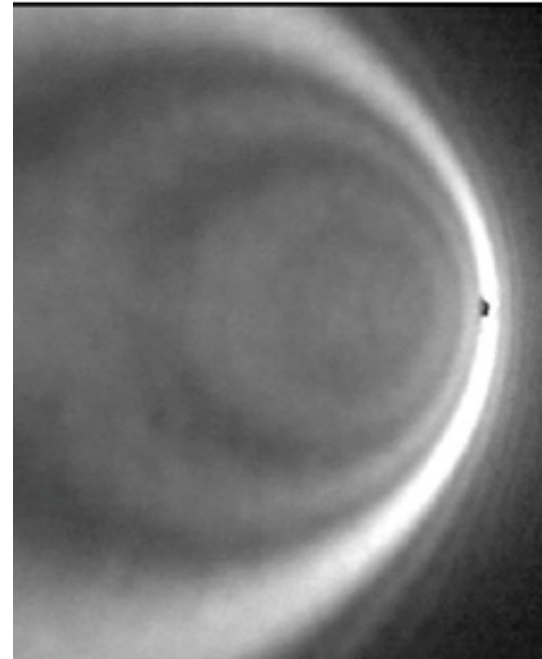

- K. Kempa, et al., "Carbon Nanotubes as Optical Antennae," *Advanced Materials*, vol. 19, 2007, pp. 421-426
- G. Y. Slepyan, et al. , "Theory of optical scattering by achiral carbon nanotubes and their potential as optical nanoantennas," *Physical Review B (Condensed Matter and Materials Physics)*, vol. 73, pp. 195416-11, 2006

CNT bundle dipole antennas

- SWCNT bundle dipole antennas
- The efficiency of a bundle antenna can be 30–40 dB higher than that of a single SWCNT dipole antenna

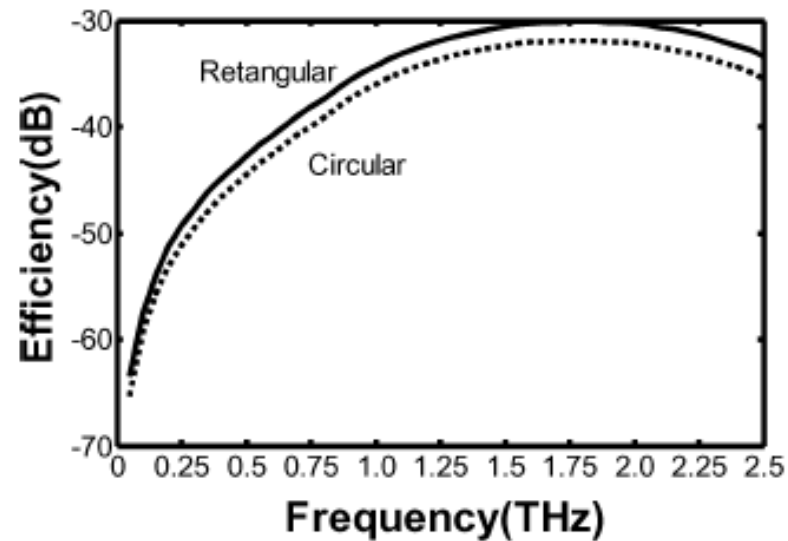
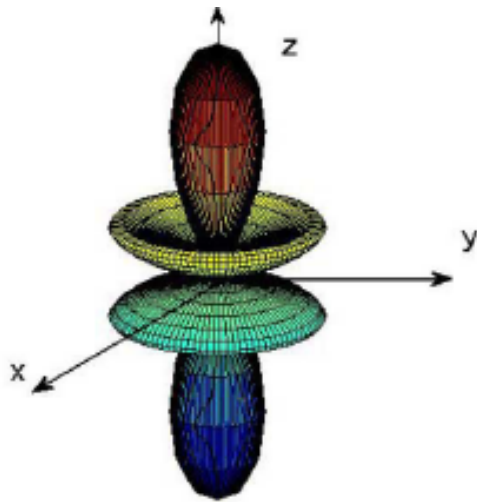

- Y. Huang et al., “Performance Prediction of Carbon Nanotube Bundle Dipole Antennas”, IEEE Transactions on Nanotechnology, Vol. 7, No. 3, May 2008, pp. 331-337

Why nanotubes for antenna application?

- Already made by nature! How else would we want to make such small structures?
- Ballistic transport and quantum conductance → low resistive loss
- Smooth, defect-free, stable and chemically complete structure → no power loss due to defects or edge and surface roughness
- Structural strength and high conductivity → high current carrying capacity (10^9 A/cm²)



Light absorption and generation in nanotubes

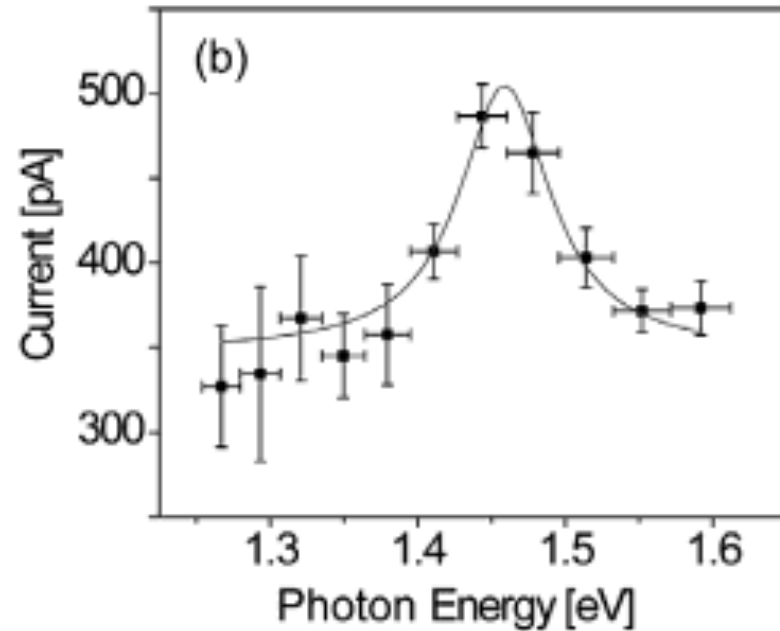
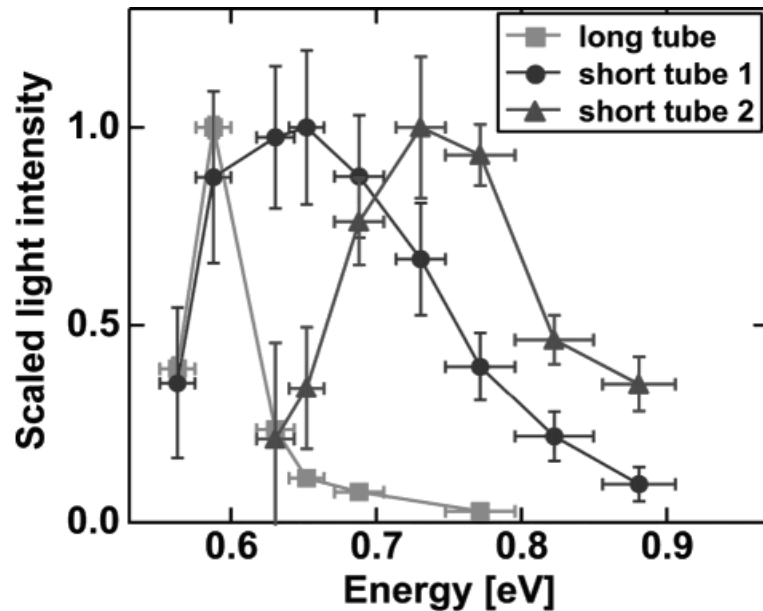

• The CNT is expected to be a linearly polarized dipole radiation source

- J. A. Misewich, R. Martel, P. Avouris, J. C. Tsang, S. Heinze, and J. Tersoff, *Science*, vol. 300, pp. 783-786, 2003.
- M. Freitag, V. Perebeinos, J. Chen, A. Stein, J. C. Tsang, J. A. Misewich, R. Martel, and P. Avouris, *Nano Letters*, vol. 4, pp. 1063-1066, 2004.

Conceptual transmitter and receiver

- About 10 different frequency channels are available.
- There is a strong polarization dependence.

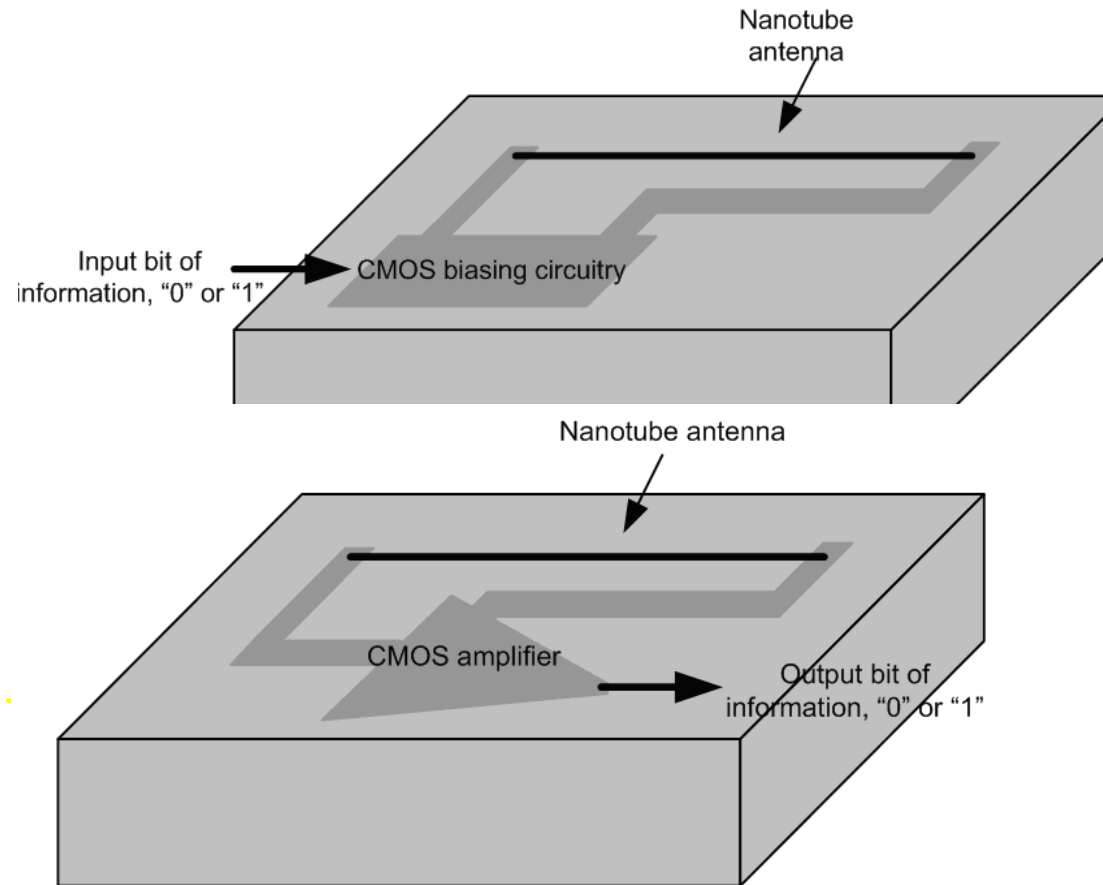

Modulation and demodulation are performed by the antenna itself!

Courtesy: Alireza Nojeh, University of British Columbia

Hybrid Wired/Wireless NoC (WiNoC)

- On-chip wireless nodes have associated overhead
- Hybrid architecture
 - Divide the whole NoC into multiple subnets
 - Communication within the subnets is still through traditional wires
 - Utilize wireless links for inter-subnet data exchange
 - Each subnet will have a wireless base station (WB)
- Subnet architectures may vary and even be heterogeneous on the same chip

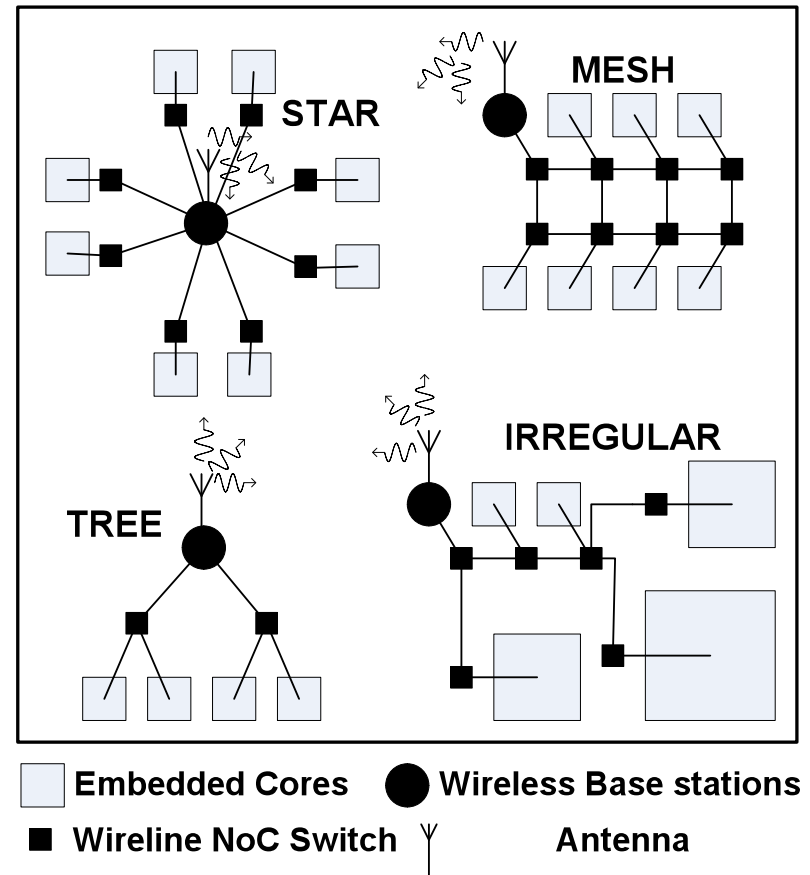

Network optimization

- Limited Wireless Resources
 - Wireless part of the network should be simple
 - Position of the WB within the subnet is important
- Connectivity in the wireless part of the network
 - Avoid multi-hop communication in the wireless channels
 - Take advantage of speed of light data transfer
 - Point-to-point wireless links
 - Adopt small-world network features
 - Enable easy scalability for larger system sizes
- Minimize the overhead
 - Avoid complicated MAC protocols



Connecting the subnets

- Small-World Nets: The Watts-Strogatz Model
- Establish high speed long distance links among distant blocks on the chip

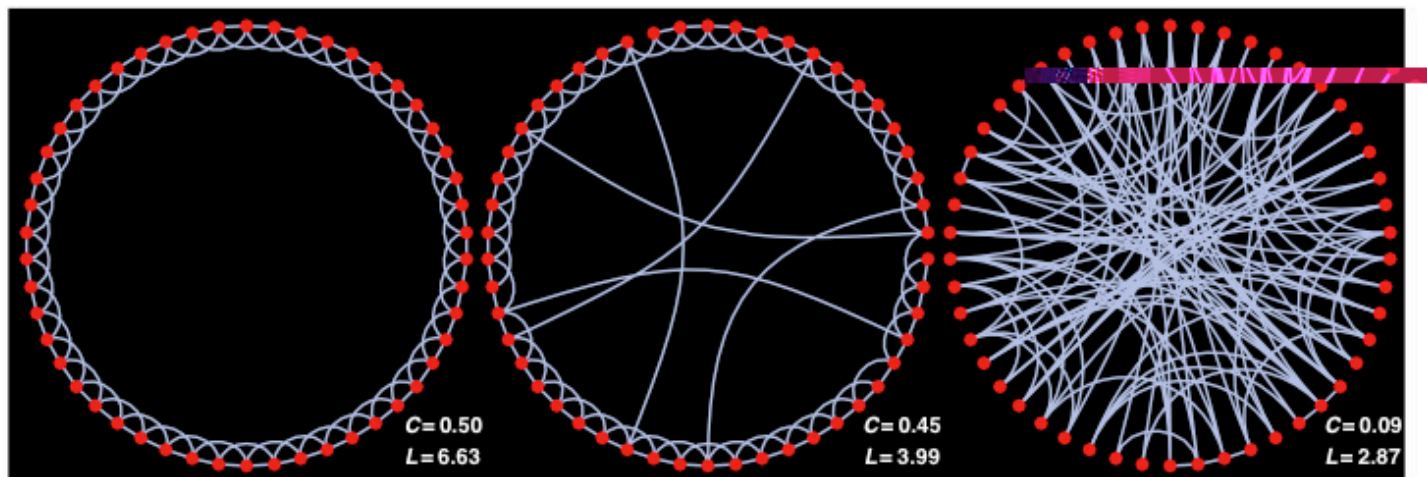

Figure 1. Watts-Strogatz model interpolates between a regular lattice (*left*) and a random graph (*right*). Randomly rewiring just a few edges (*center*) reduces the average distance between nodes, L , but has little effect on the clustering coefficient, C . The result is a “small-world” graph.

regular lattice

small-world

random graph

Courtesy: Christof Teuscher, Portland State University

Communication mechanisms with CNT antennas

- Use multiband lasers to excite the antennas
 - Electroluminescence phenomenon will eliminate this overhead
- Laser sources of different frequencies
 - Establishes a form of FDM
- Optical modulators/demodulators
- Different frequency channels can be assigned to pairs of communicating subnets
- Antenna elements tuned to different frequencies for each pair



WiNoC with small-world connections

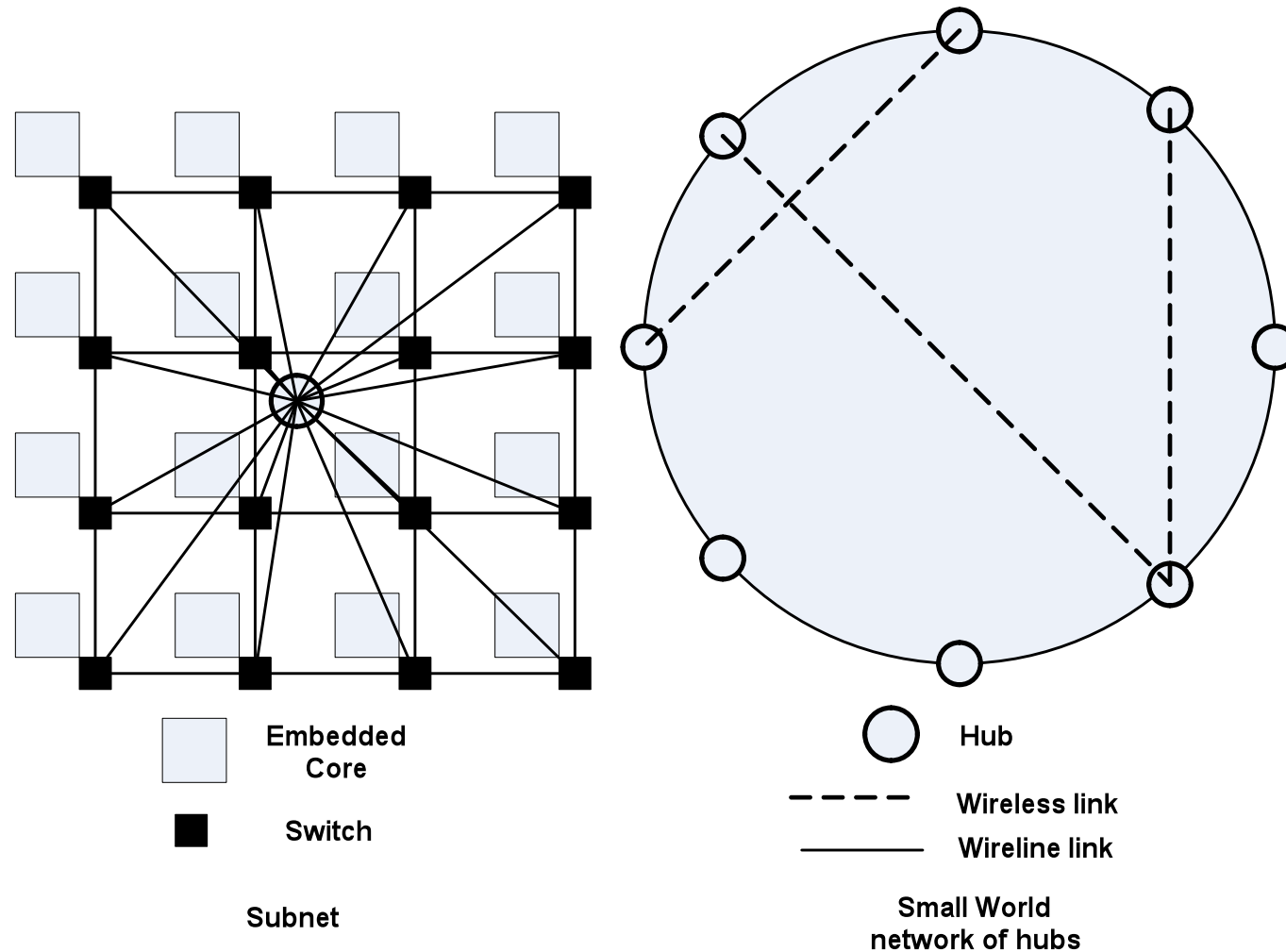

Wireless port

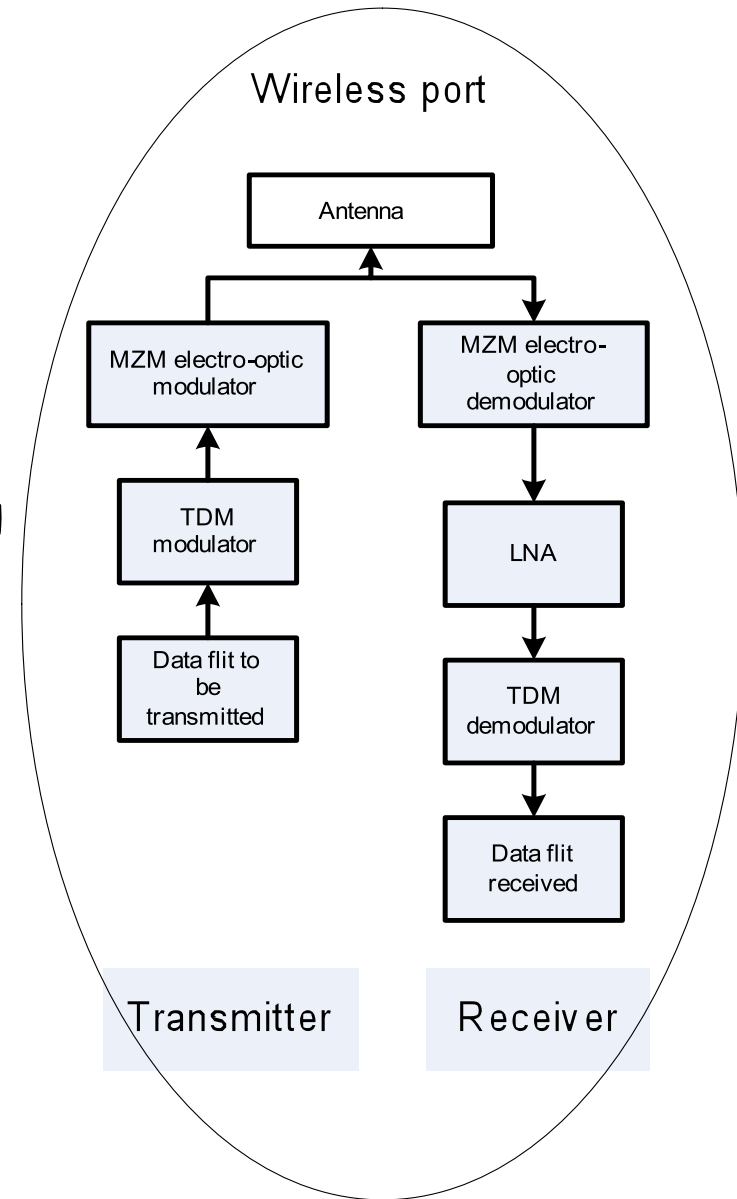
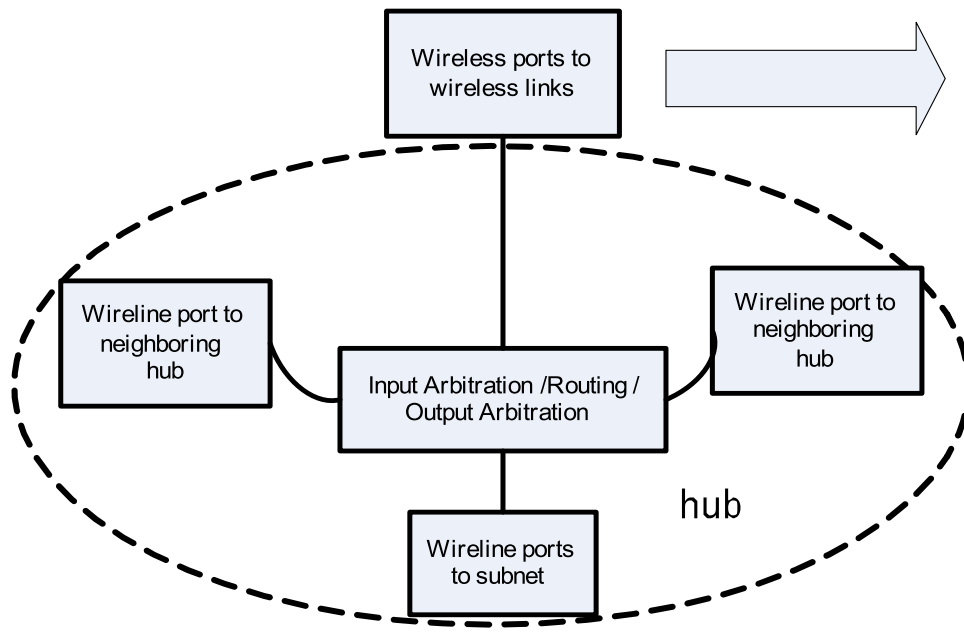

Overall channelization scheme

- 32-bit flit width
- 4 distinct frequency channels
- Combination of FDM and TDM.
- Simple on-off keying

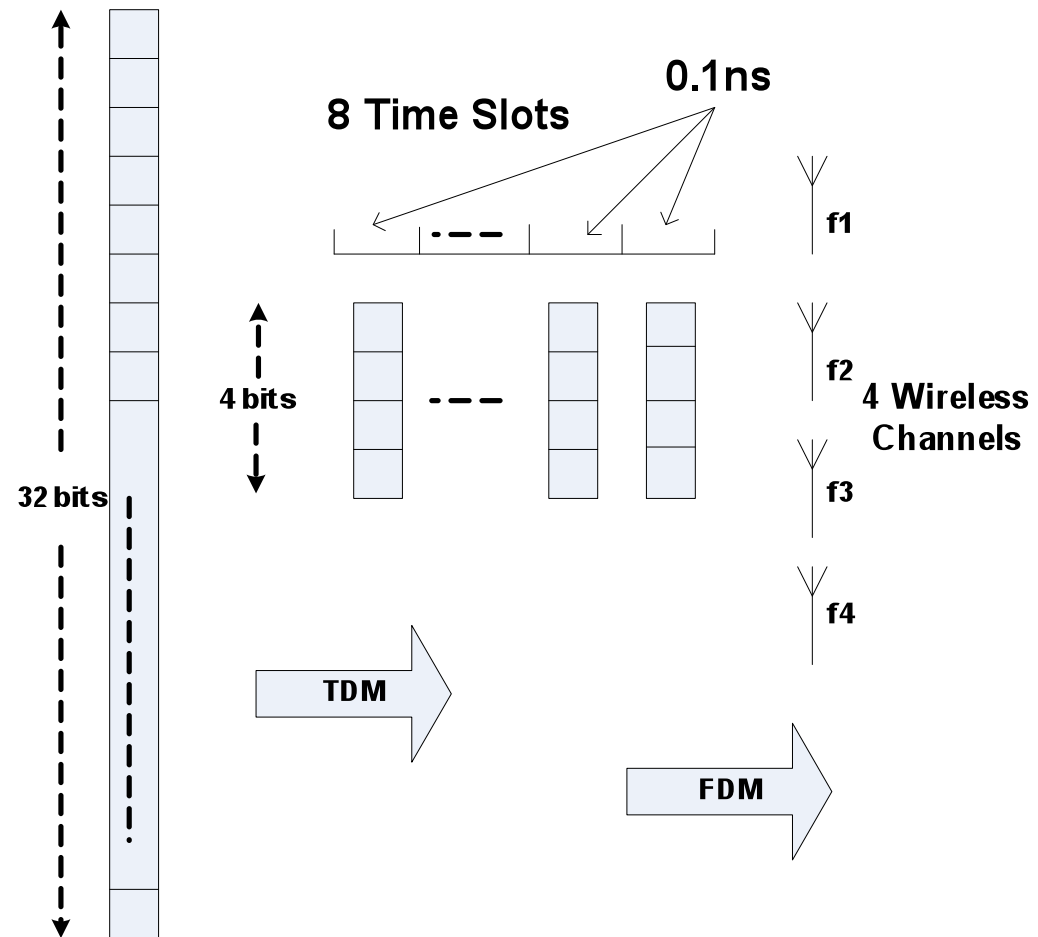

Establishing wireless links

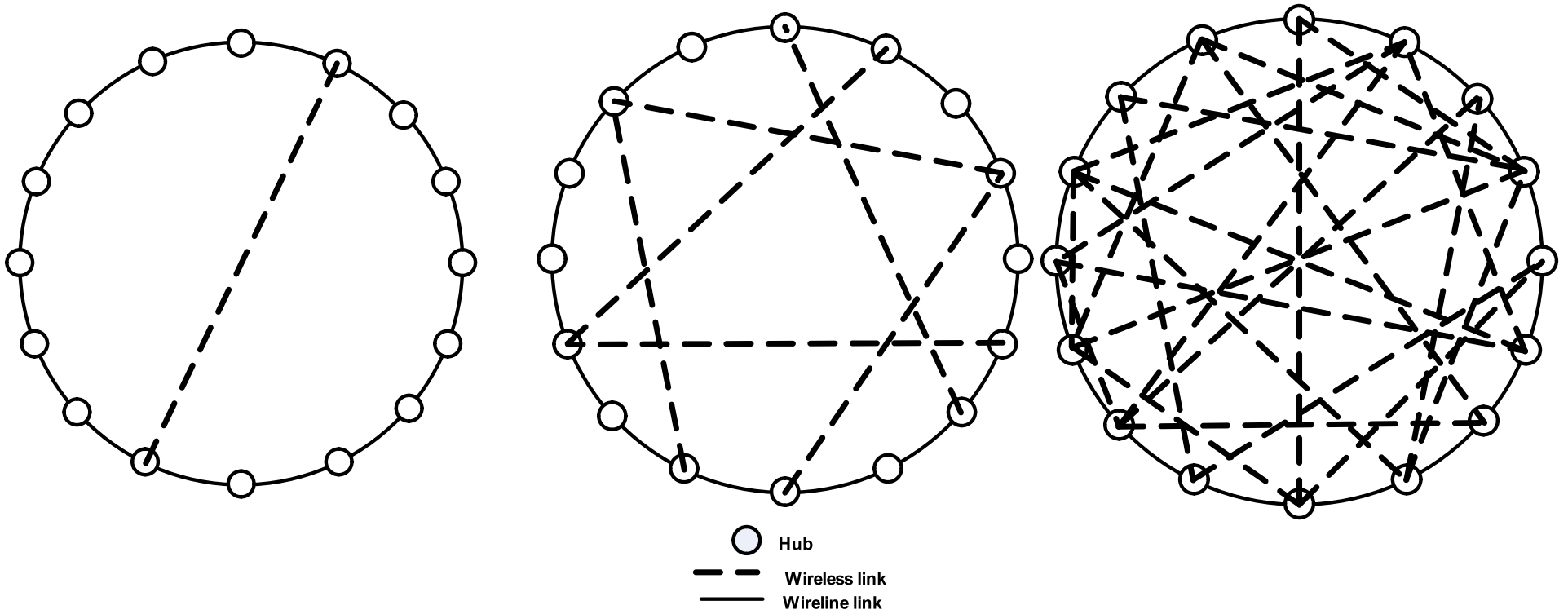

Throughput and Latency

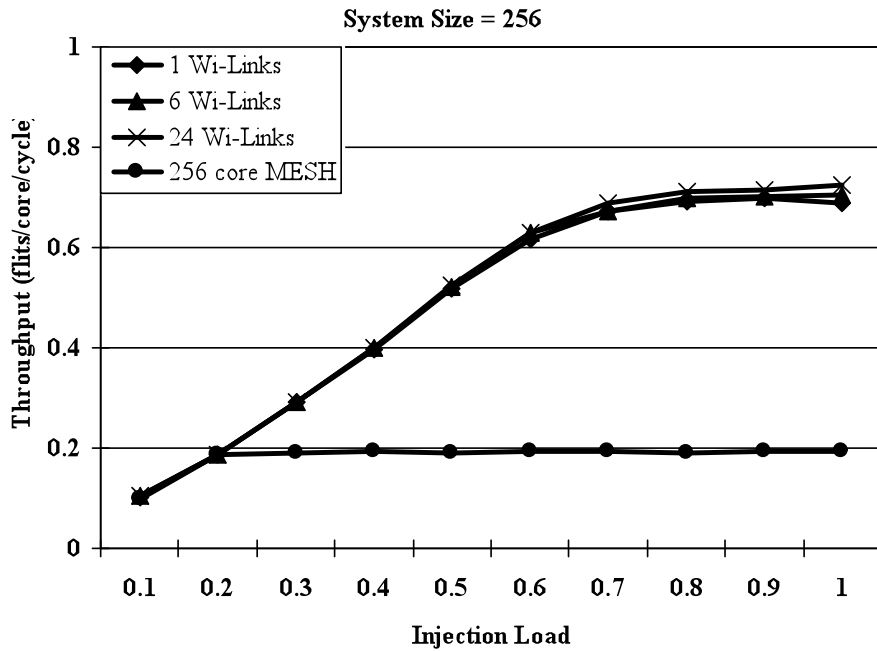

Throughput

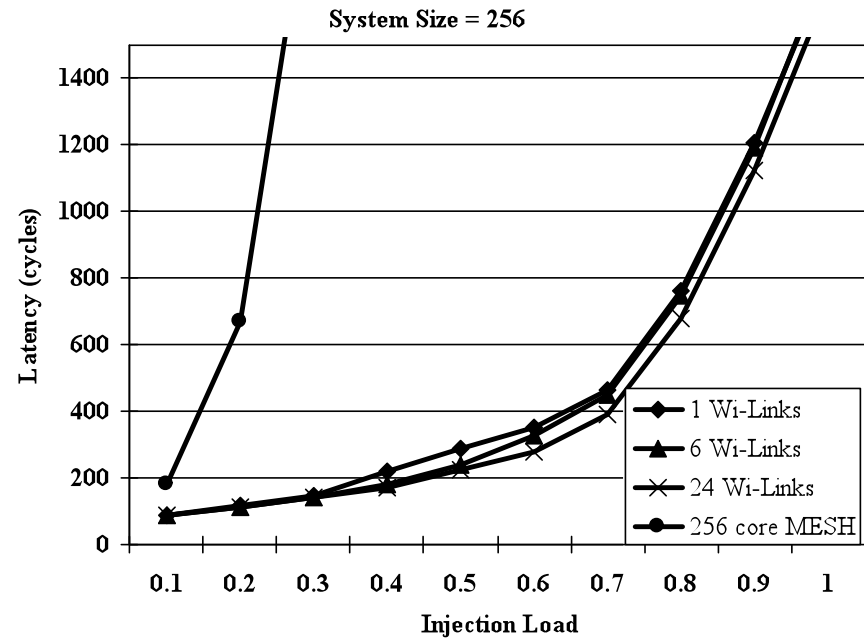

Latency

WiNoC is capable of improving performance of wireline architectures

Scaling trend

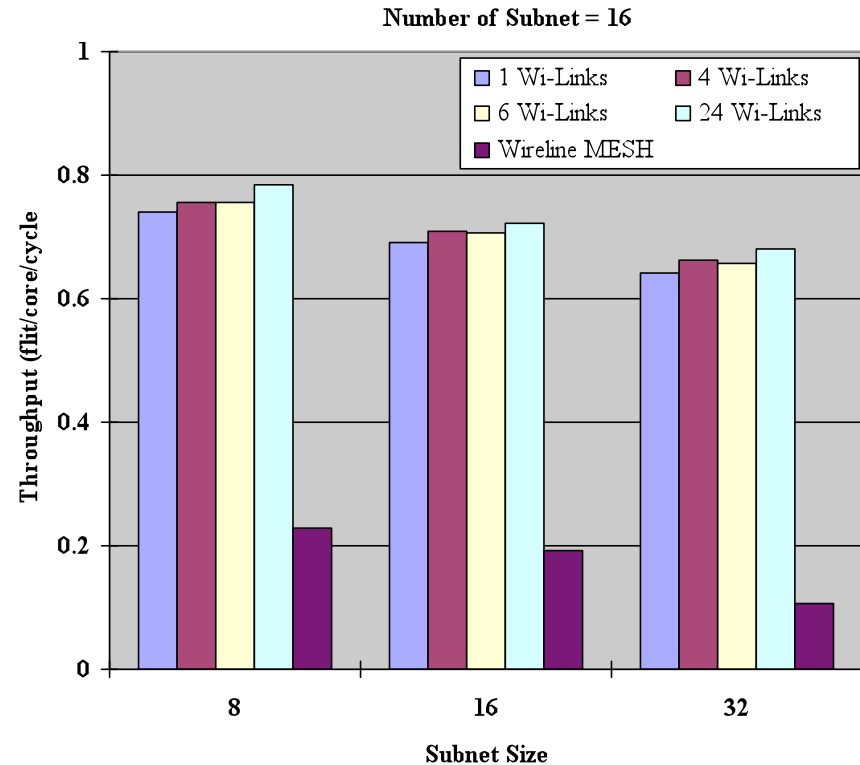
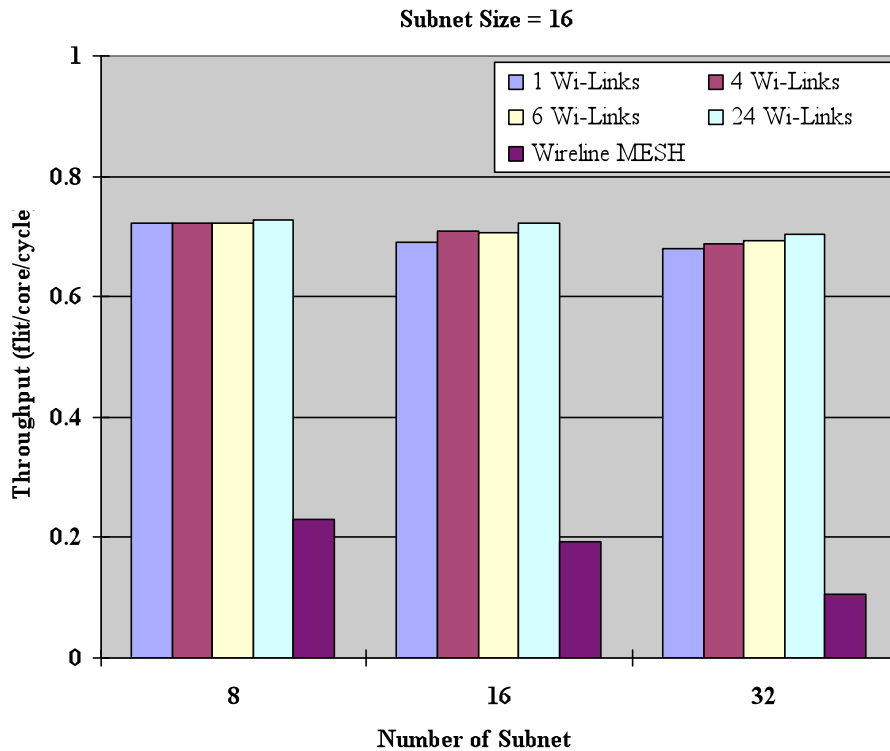

Throughput degrades more if the subnet size is increased rather than increasing the number of subnets

Summary

- WiNoCs are promising alternatives to conventional planar on-chip networks
- Capable of improving NoC performance significantly
- CNTs demonstrate interesting optical antenna properties
- WiNoCs designed with CNT antennas will have low overhead.



Road ahead

- Overall network design
 - Development of scalable wireless network
 - Network optimization
 - Partitioning of wireless and wired network
 - Reliability of the wireless channel
 - Novel ECC schemes
- CNT antennas are promising
 - But some unknowns!
- Explore the possibility of NoC with mm-wave wireless links



Acknowledgements

- Dr. Benjamin Belzer, WSU
- Dr. Deuk Heo, WSU
- Dr. Christof Teuscher, PSU
- Dr. Alireza Nojeh, UBC
- Mr. Amlan Ganguly
- Mr. Kevin Chang, WSU
- Mr. Sujay Deb, WSU

